



CONTENTS

MIG/MAG/CO₂ Torches & Parts	2-9
• CO ₂ Welding Guns	2-4
• Tip Holder Series	5
• Contact Tip Series	5
• Nozzle Series	6
• Swan Neck Series	6
• Insulator & Gas Diffuser Series	7
• Wire-Feeder Roller Series	7
• Welding Liner Series	8
• Plug Series	8
• Standard Welding Parts for Wire-Feeder	9
Plasma Cutting Torches & Consumables	10-13
• Hypertherm, Plasma Replacement Consumables	10-12
• Plasma Replacement Consumables	13
TIG Torches & Parts	14-15
• TIG Torches & Body	14
• TIG Ceramic Nozzles	14
• TIG Collets, Collet Bodies & Gas Lenses	15
• Long & Short Back Caps	15
Others :	16-20
• Regulator & Flowmeter.	16
• Tungsten Electrode.	16
• Solenoid Valve.	17
• CO ₂ Gas Pre-Heater.	17
• Welding Glass.	17
• Welding Hose & CO ₂ Welding Cable.	17
• Anti-Spatter Gel & Spray.	18
• Electrode Holder.	18
• Earth Clamp & Hose Clamp.	18
• Safety Goggle.	19
• Welding Helmet.	19
• Power Semiconductor Devices.	19
• Welding Machines & Parts.	20
• Cutting Range.	20

CO₂ Welding Guns



CO₂ Air Protective Welding Gun - Air Cooled

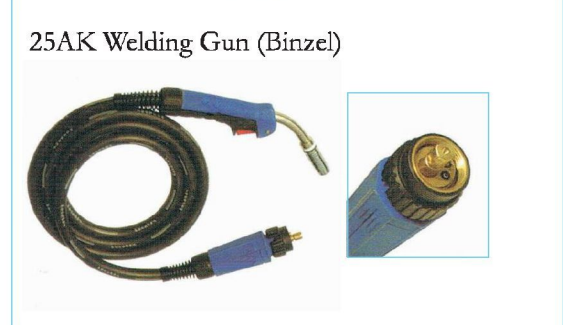
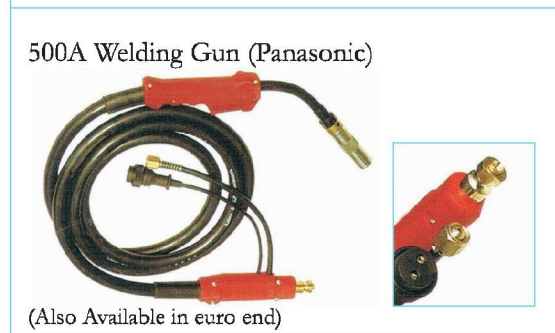

MIG/MAG/CO₂ TORCHES & SPARES

36KD Welding Gun (Binzel)

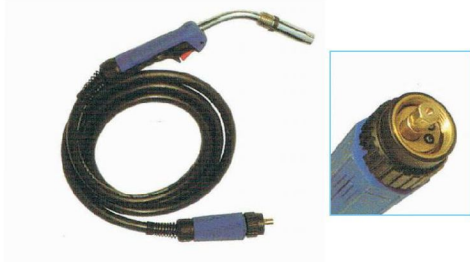

350A Welding Gun (OTC)

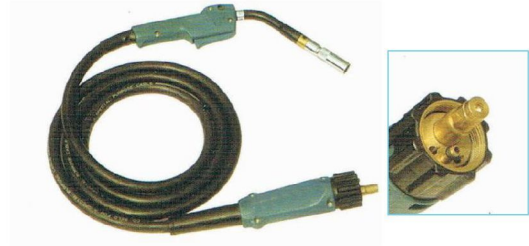

500A Welding Gun (OTC)

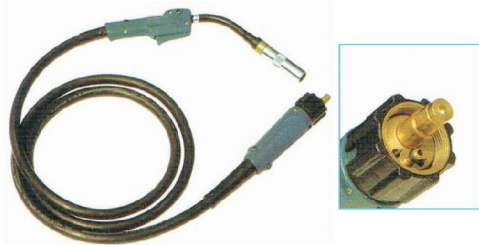

501D Water - Cooled Welding Gun (Manual)

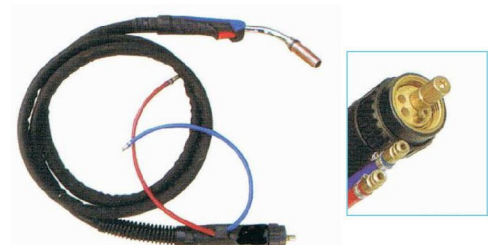

501D Water - Cooled Welding Gun (Straight, Automatic)



350A Welding Gun (Lincoln)

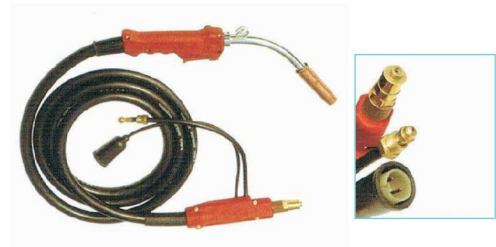

Welding Gun (Miller)

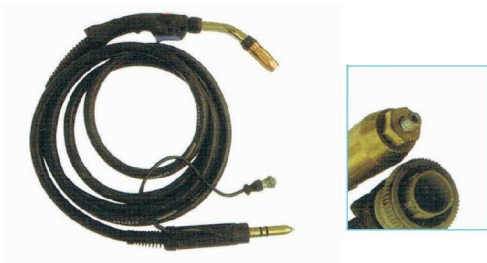

Carbon Arc Air Gouging Gun

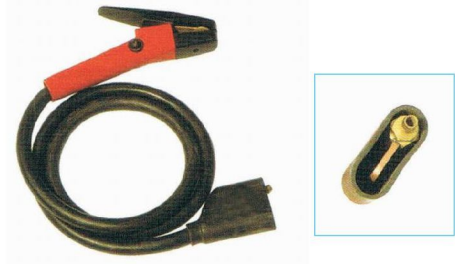

Air Cooled MIG/MAG/CO₂ Welding Torch for ESAB

PSF250

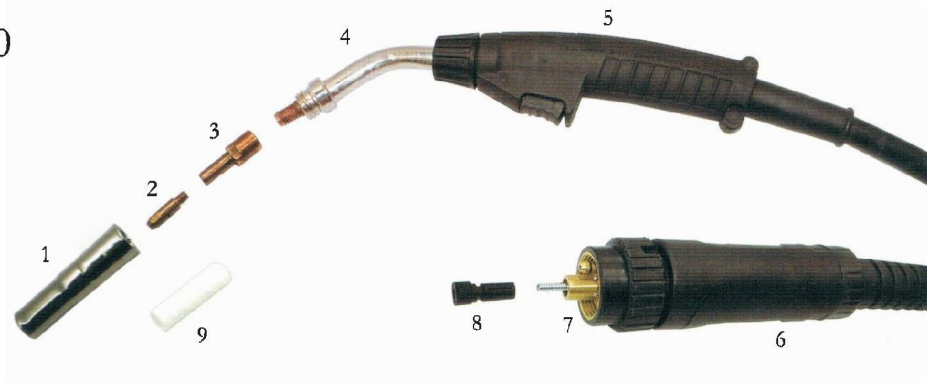

PSF405



PSF505

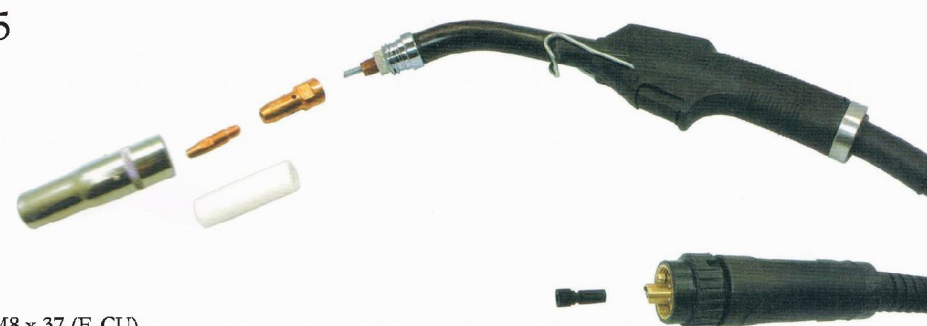

1. Nozzle (CU)
2. Contact Tip M8 x 37 (E-CU)
3. Tip Adopter (CU)
4. Swan-Neck (CU)
5. Handle (Front)
6. Handle (Rear)
7. Euro Plug
8. Liner 3.5 Mtrs.
9. Insulator

MIG/MAG/CO₂ TORCHES & SPARES

Tip Holder Series

				
200A Tip Holder (Screw Inside)	OTC 350A (Screw Inside)	Pana 350A (Screw Outside)	OTC 500A (Screw Inside)	Pana 500A (Screw Outside)
				
15AK Tip Holder (Binzel)	24KD Tip Holder (Binzel)	25AK Tip Holder (Binzel)	36KD Tip Holder (Binzel)	40KD Tip Holder (Binzel)
				
501D Tip Holder Steel Welding (Binzel)	OTC 350A Tip Holder	OTC 500A Tip Holder	Lincoln Tip Holder	Bernard Tip Holder













Contact Tip Series (In E-CU, Cucrzc) (Available in G-Tech Also)

				
Panasonic M6 x 40	Panasonic M6 x 45	15AK (Binzel)	24AK (Binzel)	36KD (Binzel)
				
Flux-Cored (Lincoln)	Fronius	Kemppi	Submerged Arc Welding Contact Tip	Submerged Arc Welding Contact Tip

Nozzle Series

				
200A Nozzle	350A Nozzle	500A Nozzle	350A Nozzle (Conical)	350A Nozzle (100mm)
				
15AK Nozzle	23KD/24KD Nozzle	25AK Nozzle	36KD Nozzle	40KD Nozzle
				
501D Nozzle	Miller New Style Nozzle	Lincoln	Kemppi	Fronius

Swan Neck Series

		
200A Swan Neck (Panasonic)	350A Swan Neck (Panasonic)	500A Swan Neck (Panasonic)
		
15AK Swan Neck (Binzel)	24KD Swan Neck (Binzel)	36KD Swan Neck (Binzel)
		
40KD Swan Neck (Binzel)	350A Swan Neck (OTC)	500A Swan Neck (OTC)
		
Swan Neck (Kemppi)	501D Swan Neck (Water - Cooled, Manual)	501D Swan Neck (Water - Cooled, Straight)

MIG/MAG/CO₂ TORCHES & SPARES

Insulator & Gas Diffuser Series

					
350A Insulator (Panasonic)	500A Insulator (Panasonic)	OTC Insulator	350A Insulator (Lincoln)	500A Insulator (Lincoln)	350A Gas Diffuser (Panasonic)
					
500A Gas Diffuser (Panasonic)	24KD Gas Diffuser (Binzel)	36KD Gas Diffuser (Binzel)	501D Gas Diffuser (Binzel)	Gas Diffuser (Fronius)	Gas Diffuser (Kemppi)

Wire - Feeder Roller Series & Switches

					
Wire Feeder Roller (Panasonic)	Wire Feeder Roller (OTC)	Wire Feeder Roller (Binzel)	Wire Feeder Roller (Binzel)	Wire Feeder Roller (Two Drives)	Wire Feeder Roller (SAF)
					
Wire Feeder Roller (Thermadyne)	Wire Feeder Roller (Thermadyne Knurled)	Wire Feeder Roller (Gear-Thermadyne)	Wire Feeder Roller (Lincoln)	Wire Feeder Roller (Kemppi)	Wire Feeder Roller (Miller)
					
Wire Feeder Roller (Miller)	Rem Wire Roller	Oerlikon Wire Roller	MIG Switch	Micro Switch	Moulded Nut (Binzel/OTC)

Welding Liner Series



Welding Liner (Miller)



Welding Liner (Miller)



Welding Liner (Binzel) 24KD/36KD



Welding Liner (Lincoln)



Welding Liner (Worked with Screw inside Swan Neck)



Welding Liner (Panasonic)



Submerge Arc Welding Liner



Welding Liner (Teflon)

Plug Series



6-Pin Plug & Socket for Pana
(3, 6, 9, 10 Pin are Available)

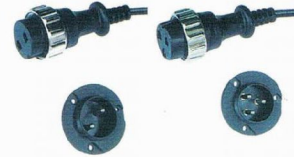

Argon Arc Welding Torch/Co₂
Reductor Plug Series
(2, 3 Pin are Available)



Plug & Socket for Pana
(2, 3 Pin are Available)

Power Plugs & Sockets



10-25mm²/35-50mm²/50-70mm²/70-90mm² are available

MIG/MAG/CO₂ TORCHES & SPARES

Standard Welding Parts for Wirefeeder

					
Wire Feeder (Panasonic/OTC)	Wire Feeder Body	Bracket KR-350/500	Servo Motor KR-350	Servo Motor KR-500	Potential Meter
					
Reel Shaft (Panasonic Style)	Reel Shaft (OTC Style)	Reel Shaft	Reel Shaft	PMDC Motor	
					
Remote Controller (Panasonic Style)	Remote Controller (Panasonic Digital)	Remote Controller (OTC Style)	OTC Pressure Roller	Panasonic Pressure Roller	
					
Handle for OTC Wire Feeder	Handle for Panasonic Wire Feeder	Flange	Tip for Wire Feeder	OutletTip for Wire Feeder	
					
European Style Plug (Binzel/Esab/OTC)	European Style Outlet (Binzel/OTC)	Euro-Style Switch to Panasonic	Adaptor (Panasonic Style)	Adaptor (OTC Style)	

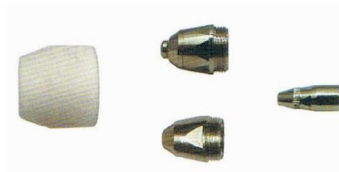

P80
Air Cooled Plasma
Cutting Torch (Pana)
Rating : 100A



P160
Water Cooled Torch
Rating : 160-200A

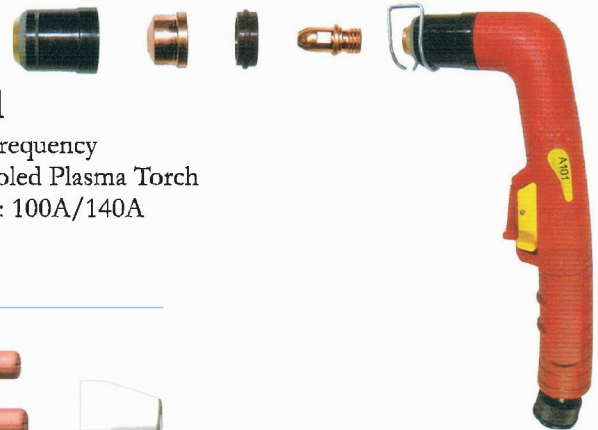

A101
High Frequency
Air Cooled Plasma Torch
Rating : 100A/140A

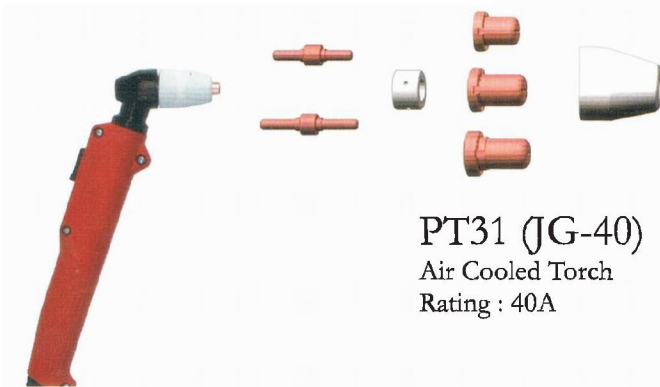

PT31 (JG-40)
Air Cooled Torch
Rating : 40A

* All the plasma consumables are manufactured using the latest CNC Machines to Provide Quality & Accuracy

PLASMA CUTTING TORCHES & CONSUMABLES



SG51
Air Cooled Plasma
Cutting Torch
Rating : 50A



SG55 (AG-60)
Air Cooled Plasma
Cutting Torch
Rating : 60A

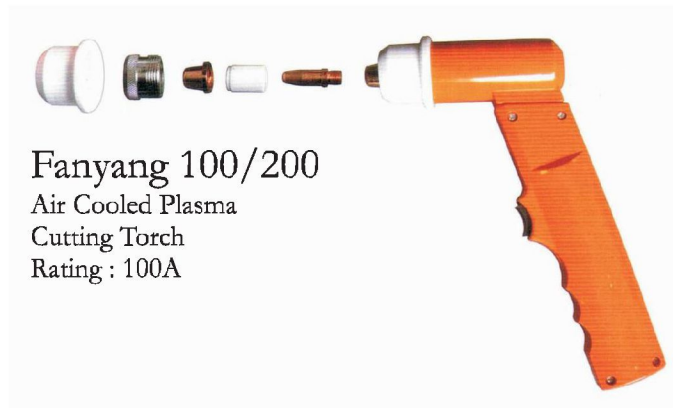

Fanyang 100/200
Air Cooled Plasma
Cutting Torch
Rating : 100A



EP



AP

* All the plasma consumables are manufactured using the latest CNC Machines to Provide Quality & Accuracy



Hypertherm Plasma Replacement Consumables

Powermax 45

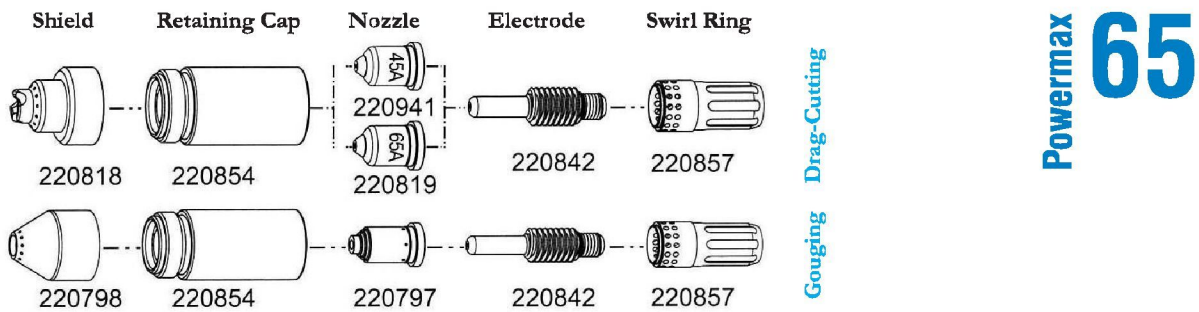
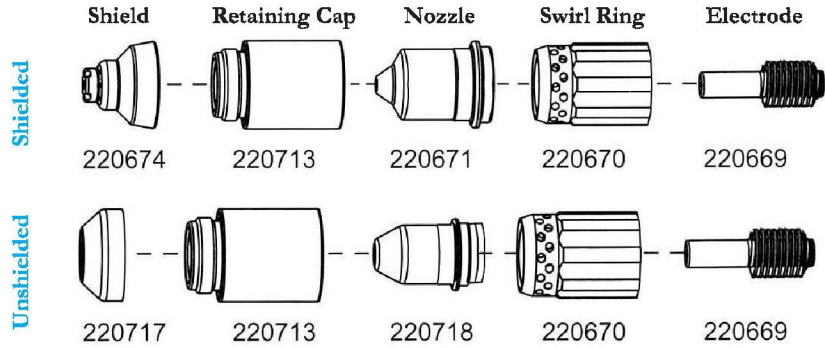

Powermax 85

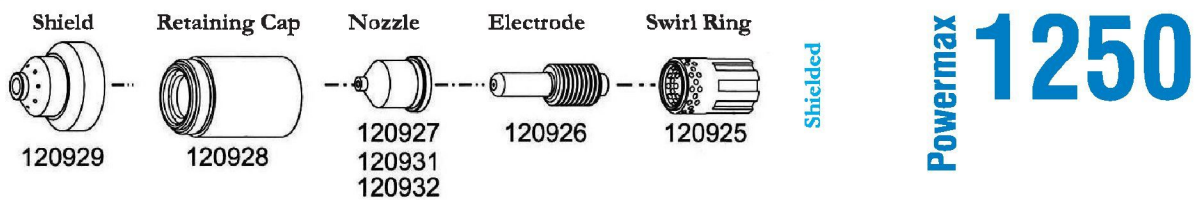
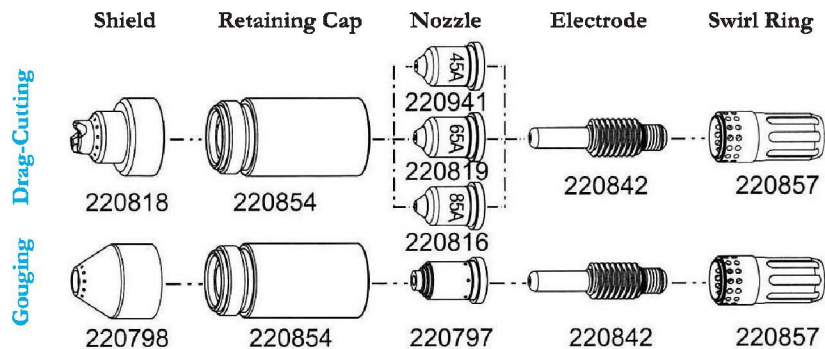

Powermax 1650

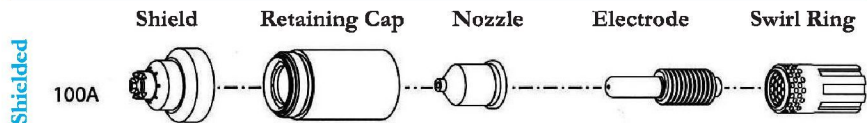

* All the plasma consumables are manufactured using the latest CNC Machines to Provide Quality & Accuracy

Plasma Replacement Consumables



AP



EP



PT-23/27

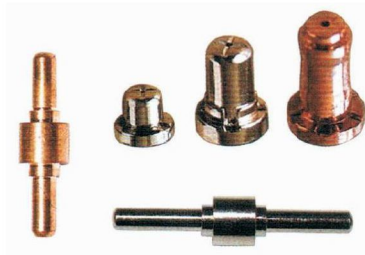

PT-31/PT31XL



PT-25



A81



A151



SG-53



SG-130



SP90



Kaliburn



Kjellberg



Thermal Dynamics



CP-200

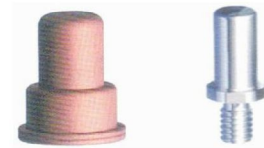

ABIPLAS PSB 31KKS

* All the plasma consumables are manufactured using the latest CNC Machines to Provide Quality & Accuracy

TIG Torches & Body



TIG Ceramic Nozzles

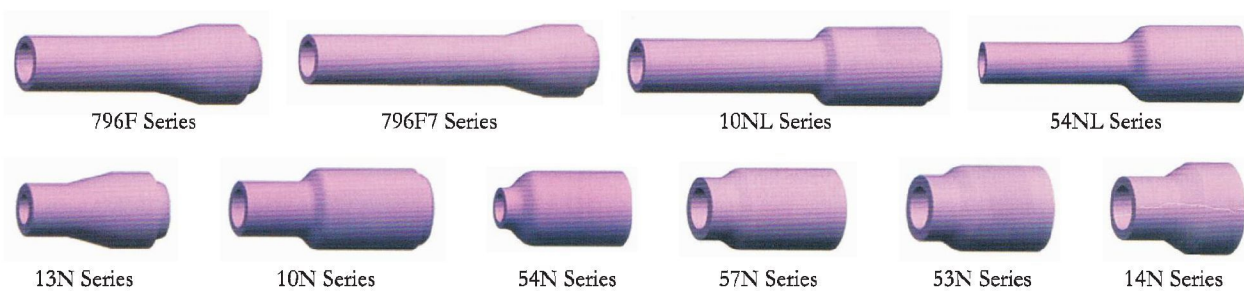

TIG TORCHES & PARTS

TIG Collets, Collet Bodies & Gas Lenses

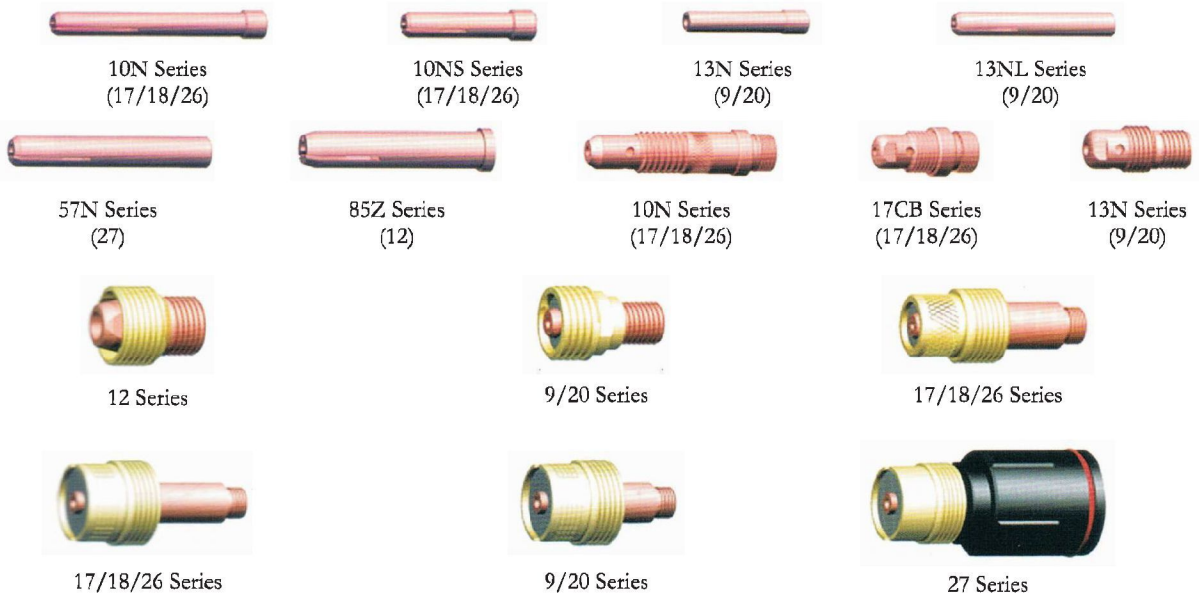

Long & Short Back Caps



Regulator & Flowmeters

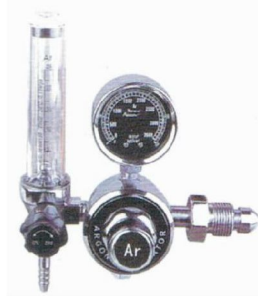

 Flowmeter (Co₂/Argon)

 Co₂ Pre-Heater
(110V/230V/36V)

 Co₂/O₂/Ar/N/DA

(Available in G-TECH, YAMATO Brand)

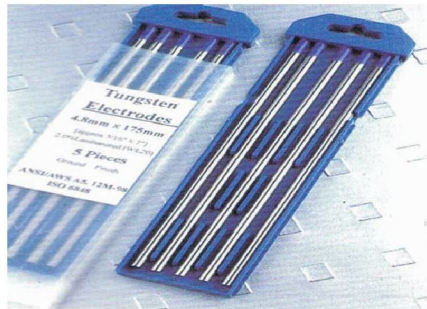
Tungsten Electrode



TYPE CODE	COLOR SIGN	CONTENT%	IMPURITY%	LENGTH mm	DIA mm
WT10	YELLOW	0.9-1.2	<0.2	75, 150, 175, 178	0.5-10.0
WT20	RED	1.8-2.2	<0.2	75, 150, 175, 178	0.5-10.0
WT30	RURPLE	2.8-3.2	<0.2	75, 150, 175, 178	0.5-10.0
WT40	ORANGE	3.8-4.2	<0.2	75, 150, 175, 178	0.5-10.0
WL10	BLACK	0.8-1.2	<0.2	75, 150, 175, 178	0.5-10.0
WL15	GOLDEN YELLOW	1.3-1.7	<0.2	75, 150, 175, 178	0.5-10.0
WL20	SKY BLUE	1.8-2.2	<0.2	75, 150, 175, 178	0.5-10.0
WC20	GREY	1.8-2.2	<0.2	75, 150, 175, 178	0.5-10.0
WP	GREEN		<0.2	75, 150, 175, 178	0.5-10.0
WY20	BLUE	1.8-2.2	<0.2	75, 150, 175, 178	0.5-10.0
WZ3	BROWN	0.2-0.4	<0.2	75, 150, 175, 178	0.5-10.0
WZ8	WHITE	0.7-0.9	<0.2	75, 150, 175, 178	0.5-10.0

OTHERS

Solenoid Valve



Available in 24V DC/42V AC/110V AC/230V AC

Co₂ Pre- Heater

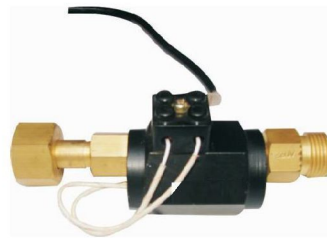

Available in 110V/230V

Welding Glass

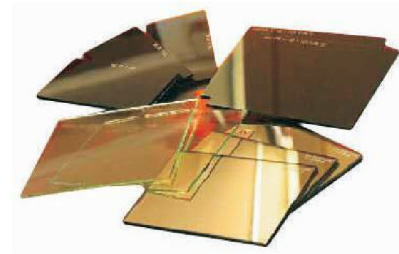

Available in 11A & 13A

Welding Hose & Co₂ Welding Cable



Available in 25mm²/35mm²/50mm²/65mm²

Anti-Spatter Gel & Spray



Electrode Holder



200A



300A



500A

Earth Clamp



300A



400A



500A

Hose Clamp (Korean)



Available in 1/2" / 3/4"



OTHERS

Safety Goggle

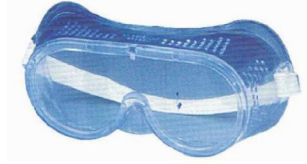

Available in Black & White

Welding Helmet



Hand -Screen



Auto-Darkening
Helmet



Head -Screen

Power Semiconductor Devices

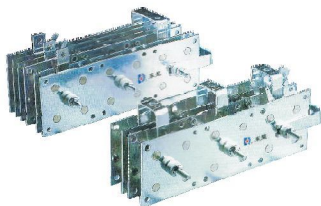

Rectifier Bridge

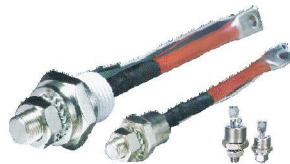

Diodes/Thyristors

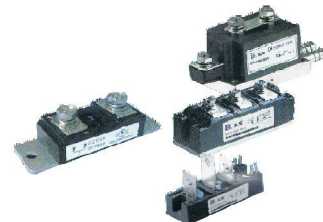

Power Modules

Welding Machines



TIG 200



ARC 250



MIG 400

Welding Machine Parts

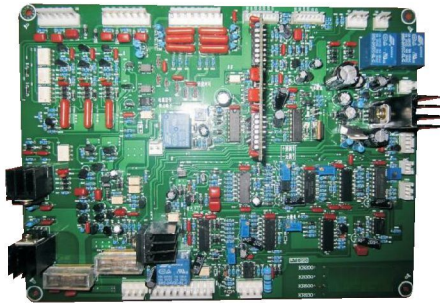

PCB Cards



CT



Switches

Cutting Range



Cutting Nozzles

Cutting Torches